

PROVEN PERFORMANCE

Customers in over 60 countries and in diverse markets and sectors.

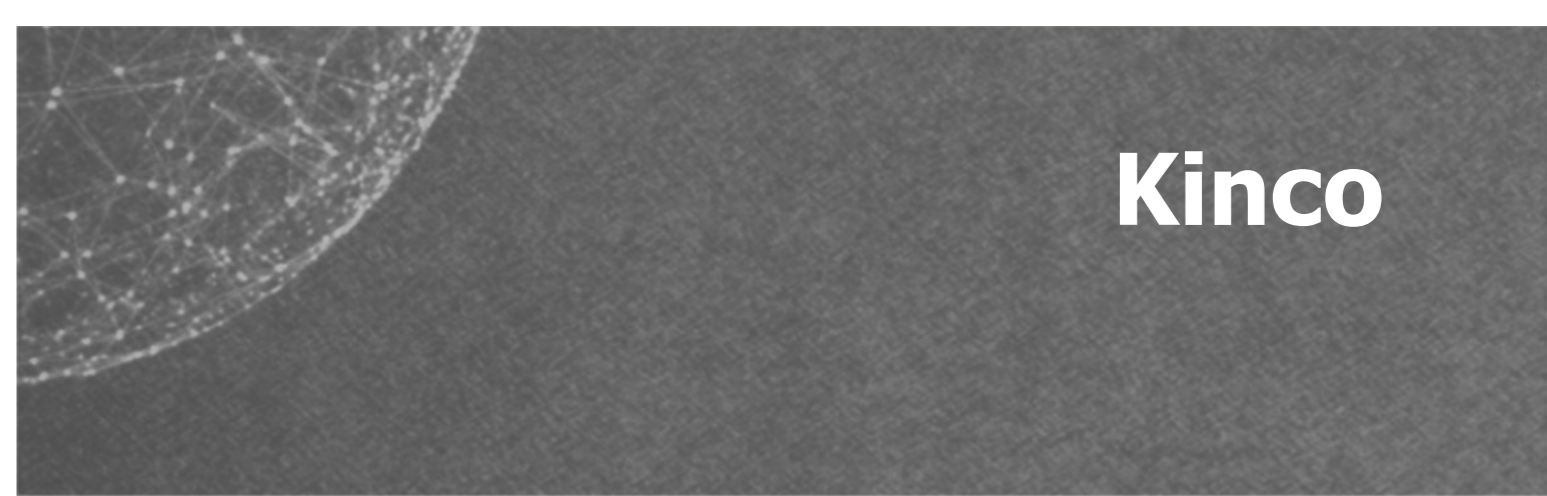

Motion Control
Servo System

Low-voltage Servo System Catalog

- iSWV: Vertical integrated steering wheel module



Kinco® Automation

en.kinco.cn Email:sales@kinco.cn

(All trademarks and logos in this brochure are property of and registered by their respective owners.)

K1E20-2603

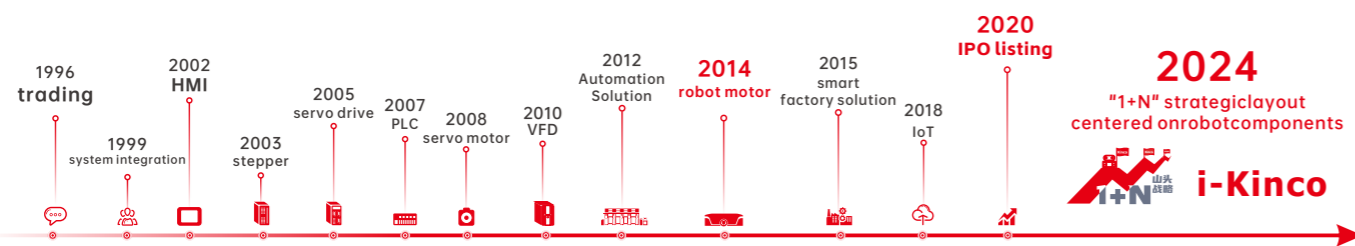

Kinco was founded in 1996, and successfully listed on the Shanghai Stock Exchange in 2020 (abbreviated name: Kinco share, stock code 688160), which is a high-tech, specialized and sophisticated enterprise that attaches great importance to independent research and development and innovation, mainly engaged in the research and development, production, sales and related technical services of industrial automation and robot core components and digital factory hardware and software. Leading Chinese supplier of motion control and human-machine interaction components for robotics and intelligent devices.

After years of continuous research and development and innovation, Kinco has established a complete product line with independent intellectual property rights, covering a series of products from machine iot to human-machine interaction, control, drive and execution, which are widely used in robots, medical equipment, logistics equipment, packaging equipment, food equipment, clothing equipment, environmental protection equipment, etc. New energy equipment, rail transit equipment and other automation equipment industry.

Based on the comprehensive industrial automation and digital technology platform, the company has in-depth application scenarios in the robot industry, providing display, control, drive and other multi-dimensional solutions for industrial mobile robots, collaborative robots, industrial robots, pan-service robots, and bionic robots. Through the insight of the industry pain points, deep links with robot customers, combined with the advantages of product research and development, the company continues to innovate, and launches industry-leading low-voltage servo products for mobile robots, integrated servo wheel, frameless torque motor for collaborative robots, robot human-machine interfaces, robot controllers and other products. The company has formed a relatively complete robot core parts capability, and after nearly 10 years of hard work in the robot industry, it has become a leading enterprise in the field of mobile robot low-voltage servo, and has a high brand influence in the industry.

Kinco has four research and development centers in Shanghai, Shenzhen, Changzhou and Chengdu, and two manufacturing bases in Shenzhen and Changzhou, a total of 10+ domestic marketing centers, 100+ domestic service providers, 40+ global partners, and products are exported to 70+ countries overseas. In terms of after-sales service, Kinco has established after-sales service centers in Shanghai, Shenzhen and Changzhou.

Four R&D centers and two manufacturing bases



Universal robots omnidirectional mobile chassis Steering wheel and walking module

As the application scenarios of wheeled humanoid robot continue to deepen, higher requirements are placed on the flexible movement of robots. Traditional differential-driven robot chassis cannot achieve lateral movement in place, have a turning radius, low operating efficiency, and do not have the ability to move in all directions. Based on this, Kinco newly launched iGML and iGMH series steering wheel travel and steering modules highly integrate core components such as servo drives, servo motors, encoders, and wheels to improve vehicle space utilization. Based on Buke's iGML and iGMH series steering wheel travel and steering modules, a four-walking and four-steering omnidirectional mobile chassis can be constructed, which can achieve straight travel, lateral movement, etc., can cleverly adapt to narrow alleys and narrow turning spaces, and has omnidirectional travel capabilities.



Feature

Highly integrated : The driver, motor and reducer are integrated into a module type with a compact structure, which is conducive to high-level control of the entire machine;

High reliability: The integrated module has only power and communication cables on the outside, and has strong anti-interference capabilities, which helps improve the stability and reliability of the entire vehicle;

Open design: The travel and rotation modules can be sold separately, and customers can design the entire module according to their own vehicle body, which has strong plasticity;

Good maintainability: A single supplier for integrated products is beneficial for subsequent product maintenance and reduces supply chain and after-sales costs;

Application scenarios: Wheeled humanoid robots, service robots, and hybrid robots

Application Scene



02 Product Features

Product Features

03 Naming Rule

Naming Rule

05 Product presentation

Technical Specifications

Terminal Description & Wiring

Accessories

Wiring Diagram

Dimensional Drawing

TN Curve

Naming Rules

Integrated Module

iSWV Naming Rules

iSWV 009 28 - 006 27 - A 130 - M A D T - AA

① ② ③ ④ ⑤ ⑥ ⑦ ⑧ ⑨ ⑩ ⑪ ⑫



①-Series name	iSWV:Vertical integrated steering wheel module	⑦-Wheel outer diameter	130:130mm
②-Walking torque	009 : 9Nm	⑧-Encoder type	M : Single turn communication type magnetoelectric encoder
③-Walking Speed	28 : 28*10rpm	⑨-Brake	A : Without brake
④-Rotating torque	006 : 6Nm	⑩-Supply voltage	D : DC48V
⑤-Rotating Speed	27:27*10rpm	⑪-Connection method	T : Standard connector
⑥-Wheel Covering Material/Pattern Type	A : Polyurethane/Raise d crss-section,diamond pattern	⑫-Contro mode	AA : RS485、CANopen EA : RS485、EtherCAT

Walking Motor Module

iGML Naming Rules

iGML 060 10 - 009 28 - A 130 - M A D T - AA

① ② ③ ④ ⑤ ⑥ ⑦ ⑧ ⑨ ⑩ ⑪ ⑫

①-Series name	iGML: Integrated Wheel Reducer Motor	⑦-Wheel outer diameter	130:130mm
②-Motor stator outer diameter	060:60mm	⑧-Encoder type	M : Single turn communication type magnetoelectric encoder
③-Reducer speed ratio	10:10 speed ratio	⑨-Brake	A : Without brake
④-Rated torque	009 : 9Nm	⑩-Supply voltage	D : DC48V
⑤-Wheel speed (after reducer output)	28 : 28*10rpm	⑪-Connection method	T: Fixed cable
⑥-Wheel Covering Material/Pattern Type	A:Polyurethane/Raise d crss-section,diamond pattern	⑫-Contro mode	AA : RS485、CANopen EA : RS485、EtherCAT

Naming Rules

Steering Motor Module

iGMH Naming Rules

iGMH 068 09 - 006 27 - L A D R - AA

① ② ③ ④ ⑤ ⑥ ⑦ ⑧ ⑨ ⑩

①-Series name	iGMH: Integrated hollow reducer motor	⑥-Encoder type	L : Communication-type inductance encoder
②-Motor stator outer diameter	068:68mm	⑦-Brake	A : Without brake
③-Reducer speed ratio	09=9 speed ratio	⑧-Supply voltage	D : DC48V
④-Rated torque	006 : 6Nm	⑨-Connection method	R : Ordinary plug
⑤-Wheel speed (after reducer output)	27 : 27*10rpm	⑩-Contro mode	AA : RS485、CANopen EA : RS485、EtherCAT

Parameter specifications

(Integrated Module) Model	iSWV00928-00627-A130-MADT-□A
Power Supply(VDC)	48V
Logic Power(VDC)	24V,0.5A(Optional)
Walking Motor Module	
Model	iGML06010-00928-A130-MADT-□A
Performance parameters of walking integrated machine	
Rated Power(W)	294
Rated Current(A)	8.5
Rated Torque(N.m)	1
Rated Speed(rpm)	2800
Maximum Current(Arms)	25
Brake Holding Torque T(Nm)	/
Performance parameters of walking integrated machine with gearbox	
Rated Torque With Gearbox(N.m)	9
Rated Speed With Gearbox(rpm)	280
Rated Power(W)	264
Wheel Diameter(mm)	130
Wheel Width(mm)	30
Rated Linear Speed(m/s)	1.9
Maximum Linear Speed(m/s)	2.2
Weight With Gearbox(kg)	3.4
Insulation Class	F
Protection Degree	IP54
Steering Motor Module	
Model	iGMH06809-00627-LADR-□A
Performance parameters of rotating integrated machine	
Rated Power(W)	195
Rated Current(A)	6.5
Rated Torque(N.m)	0.75
Rated Speed(rpm)	2500
Max Current(Arms)	14.3
Performance parameters of rotating integrated machine with gearbox	
Rated Torque With Gearbox(N.m)	6
Rated Speed With Gearbox(rpm)	277
Rated Power(W)	174
MaxTorque With Gearbox(N.m)	13.5
Max Speed With Gearbox(rpm)	330
Weight With Gearbox(kg)	0.88
Insulation Class	F
Protection Degree	IP20
Integrated Module	
Overall Parameters	
Overall weight (kg)	4.7
Tire Material	Polyurethane
Tire Hardness Rating	85A ± 2
Working System	S3-10min-60%(Cycle 10min,60% Working hours)
Carrying weight (kg)	Max 100kg
Energy Consumption Brake	The walking module contains a braking circuit
Overvoltage Alarm(V)	Default 68±2V
Undervoltage Alarm(V)	Default 18±2V
Modbus/RS485	Supports a Max baud rate of 115.2Kbps and can communicate with the controller using the Modbus RTU protocol
CANopen	Supports a Max baud rate of 1Mbps and can communicate with the controller using the CANopen protocol
EtherCAT	Support CoE(CIA402 protocol)and CSP/CSV/PP/PV/PT/HM mode, communication speed 100M
Environmental Conditions	Working environment temperature:0°C~40°C;Storage temperature:-20°C~+60°C; 90%RH(below) for use and storage, non-condensation;Polyurethane tread requires a flat road surface and no foreign objects.

Note □=A : RS485、CANopen
E : RS485、EtherCAT

iSWV-AA model

iSWV-AA_Walking Motor Module Interface Instructions

IO
MOLEX 430201800

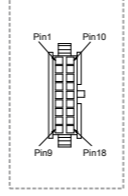

PIN	Signal	Color	PIN	Signal	Color
1	GNDS	White	10	RS485A	Purple
2	DI1	Pink	11	CANL	Blue-White
3	COMI	Gray	12	CANL	White-Orange
4	DI2	Red	13	CANH	Blue
5	/	\	14	CANH	Orange
6	GND C	Brown	15	120-R1	Green
7	120-R2	White-Green	16	PE	Yellow-Green
8	24VS	Black	17	/	\
9	RS485B	Yellow	18	/	\

PIN	Signal	Pin function
1	GNDS	Logic electrical reference ground
8	24VS	Logic power input positive terminal (optional), Max input current 0.5A
2	DI1	Digital signal input, COMI terminal; High level: 12.5 ~ 30VDC
4	DI2	Low level: 0 ~ 5VDC Input impedance: 5KΩ Maximum frequency: 1KHz
3	COMI	Digital signal input common end
6	GND C	Communication signal ground
9	RS485B	RS485 data negative end
10	RS485A	RS485 data positive end
11	CANL	CAN signal negative end
12	CANL	
13	CANH	CAN signal positive end
14	CANH	
15	120-R1	120-R1 and 120-R2 are short-circuited,
7	120-R2	CAN communication terminal resistor takes effect
16	PE	Ground terminal

Power
C6350HM-3P-V0

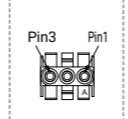

PIN	Signal	Color	Pin function
1	DC+	Black	The input end of the power supply of the driver must be connected. Input voltage:24~60VDC
3	DC-	Red	

Brake Resistance
C6350HM-2P-V0

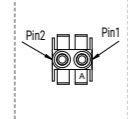

PIN	Signal	Color	Pin function
1	RB+	Brown	External braking resistor input terminal
2	RB-	Blue	

iSWV-AA_Steering Motor Module Port Instructions

IO
X2026WV-2x4B-N0SN

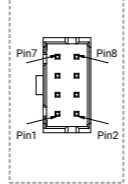

PIN	Signal	Pin function
1	DI2	Digital signal input, COMI terminal; High level: 12.5 ~ 30VDC
3	DI1	Low level: 0 ~ 5VDC Input impedance: 5KΩ Maximum frequency: 1KHz
2	D01	Digital signal output, OUT1 for the open collector output, the highest voltage 30V, driving capacity of 100mA
4	COM0	Digital signal output common end
6	COMI	Digital signal input common end
7	24VS	Logic power input positive terminal (optional), Max input current 0.5A Note: When using the sensor, Must be connected
8	GNDS	Logic electrical reference ground

120R
A2006WVVB-2x2P

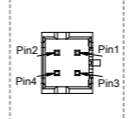

PIN	Signal	Pin function
2	120-R2	120-R1 and 120-R2 are short-circuited, CAN communication terminal resistor takes effect
4	120-R1	

Sensor
A2006WVVB-2x2P

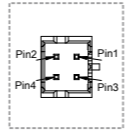

PIN	Signal	Pin function
1	GND	Reference ground
2	24V	24V power output positive, Max input current 0.5A. Note: When using the sensor (SEN), the logic power must be connected.
3	DI3	Sensor signal input terminal Note: This interface can only connect to proximity sensors and cannot be used as a digital signal input. The standard product does not support this function by default. You can contact the sales department to customize this function.

Battery
X2011WV-02A-N0SN

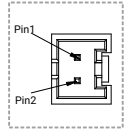

PIN	Signal	Pin function
1	BAT-	Encoder battery -
2	BAT+	Encoder battery +

Power
XT30UPB-M

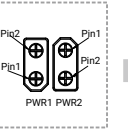

PIN	Signal	Pin function
1	DC-	Input voltage:24~60VDC, Max input current: 16A
2	DC+	

CANopen
A2006WVVB-2x2P

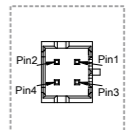

PIN	Signal
1	CANL
2	CANH
3	CANL
4	CANH

RS485
A2006WVVB-2x2P

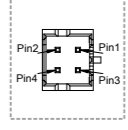

PIN	Signal
1	485B
2	485A
3	485B
4	485A

Note: Choose either PWR1 or PWR2.

iSWV-EA model

■ iSWV-EA_Walking Motor Module Interface Instructions

IO
MOLEX 430201000

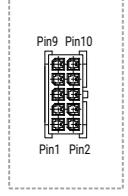

PIN	Signal	Color	Pin function
1	24VS	Black	Logic power input positive terminal (optional), Max input current 0.5A
2	GNDS	White	Logic electrical reference ground
3	DI2	Red	Digital signal input, COMI terminal; High level: 12.5 ~ 30VDC
5	DI1	Pink	Low level: 0 ~ 5VDC Input impedance: 5KΩ Maximum frequency: 1KHz
4	COMI	Gray	Digital signal input common end
7	RS485A	Purple	RS485 data positive end
8	RS485B	Yellow-Green	RS485 data negative end
9	PE	Yellow-Green	Ground terminal
10	/		

EtherCAT
MOLEX 430200400

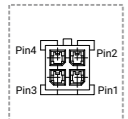

PIN	EtherCAT In	Color	EtherCAT Out	Color
1	IN_TX-	Brown	OUT_TX-	Orange
2	IN_RX+	White-Green	OUT_RX+	Blue-White
3	IN_TX+	White-Brown	OUT_TX+	White-Orange
4	IN_RX-	Green	OUT_RX-	Blue

Brake Resistance
C6350HM-2P-V0

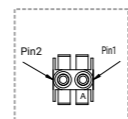

PIN	Signal	Color	Pin function
1	RB+	Brown	External braking resistor input terminal
2	RB-	Blue	

Power
C6350HM-3P-V0

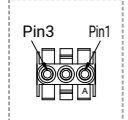

PIN	Signal	Color	Pin function
1	DC+	BLACK	The input end of the power supply of the driver must be connected.
3	DC-	RED	Input voltage:24~60VDC

■ iSWV-EA_Steering Motor Module Port Instructions

IO
X2026WV-2X4B-N0SN

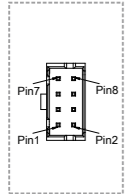

PIN	Signal	Pin function
1	DI2	Digital signal input, COMI terminal; High level: 12.5 ~ 30VDC
3	DI1	Low level: 0 ~ 5VDC Input impedance: 5KΩ Maximum frequency: 1KHz
2	D01	Digital signal output, OUT1 for the open collector output, the highest voltage 30V, driving capacity of 100mA
4	COM0	Digital signal output common end
6	COMI	Digital signal input common end
7	24VS	Logic power input positive terminal (optional), Max input current 0.5A Note: When using the sensor, Must be connected
8	GNDS	Logic electrical reference ground

EtherCAT
A2006WVB-2x2P

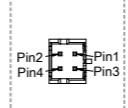

PIN	EtherCAT In	EtherCAT Out
1	IN_TX-	OUT_TX-
2	IN_RX+	OUT_RX+
3	IN_TX+	OUT_TX+
4	IN_RX-	OUT_RX-

RS485
A2006WVB-2x2P

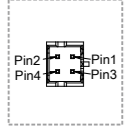

PIN	Signal
1	485B
2	485A
3	485B
4	485A

Battery
X2011WV-02A-N0SN

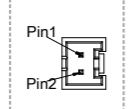

PIN	Signal	Pin function
1	BAT-	Encoder battery -
2	BAT+	Encoder battery +

Power
XT30UPB-M

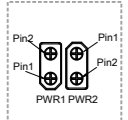

PIN	Signal	Pin function
1	DC-	Input voltage:24~60VDC, Max input current: 16A
2	DC+	

Note: Choose either PWR1 or PWR2.

Attachment

■ Walking Motor Module:iGML06010-00928-A130-MADT-AA

Interface	Models
	External cable terminal package
Accessory package	iWMC10411-04023-A180-MBDT Accessory package
	External connection cable
IO	EXC-iGML-AA-A6-IO
Power	EXC-iGML-AA-A6-Power
Brake Resistance	EXC-iGML-AA-A6-BRA

Note 1: Accessory package comes with the packaging.
Note 2: External connection cable needs to be purchased separately.

■ Steering Motor Module:iGMH06809-00627-LADR-AA

Interface	Models
	External cable terminal package
Accessory package	iGMH06809-00627-LADR-AA Accessory package
	External connection cable
IO	EXC-iGMH-AA-A6-IO
120R	
CAN	EXC-iGMH-EA-A6-EC
485	
BAT	BAT-iGMH
PWR1	
PWR2	EXC-iGMH-AA-A6-PWR

Note 1: Accessory package comes with the packaging.
Note 2: External connection cable needs to be purchased separately.

■ Walking Motor Module:iGML06010-00928-A130-MADT-EA

Interface	Models
	External cable terminal package
Accessory package	iGML06010-00928-A130-MADT-EA Accessory package
	External connection cable
EC IN	EXC-iGML-EA-A6-EC
EC OUT	
IO	EXC-iGML-EA-A6-IO
Power	EXC-iGML-AA-A6-Power
Brake Resistance	EXC-iGML-AA-A6-BRA

Note 1: Accessory package comes with the packaging.
Note 2: External connection cable needs to be purchased separately.

■ Steering Motor Module:iGMH06809-00627-LADR-EA

Interface	Models
	External cable terminal package
Accessory package	iGMH06809-00627-LADR-AA Accessory package
	External connection cable
IO	EXC-iGMH-AA-A6-IO
EC IN	
EC OUT	①EXC-iGMH-EA-A6-EC
485	②EXC-iGMH-EA-A6-EC-01
BAT	BAT-iGMH
PWR1	
PWR2	EXC-iGMH-AA-A6-PWR

Note 1: Accessory package comes with the packaging.
Note 2: External connection cable needs to be purchased separately.
Note 3: ①Terminal + Shielded wire twisted pair 600mm + Loose wire;
②Terminal + Shielded wire twisted pair 600mm + Terminal.

iSWV series electrical wiring

■ iSWV-AA electrical wiring

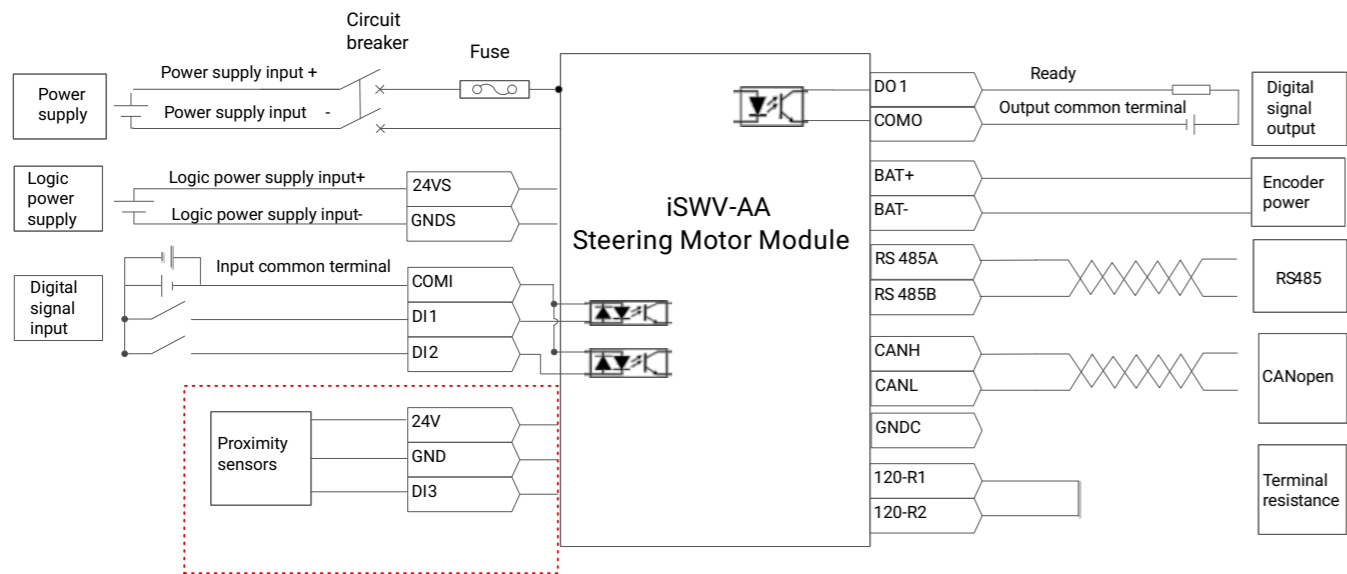
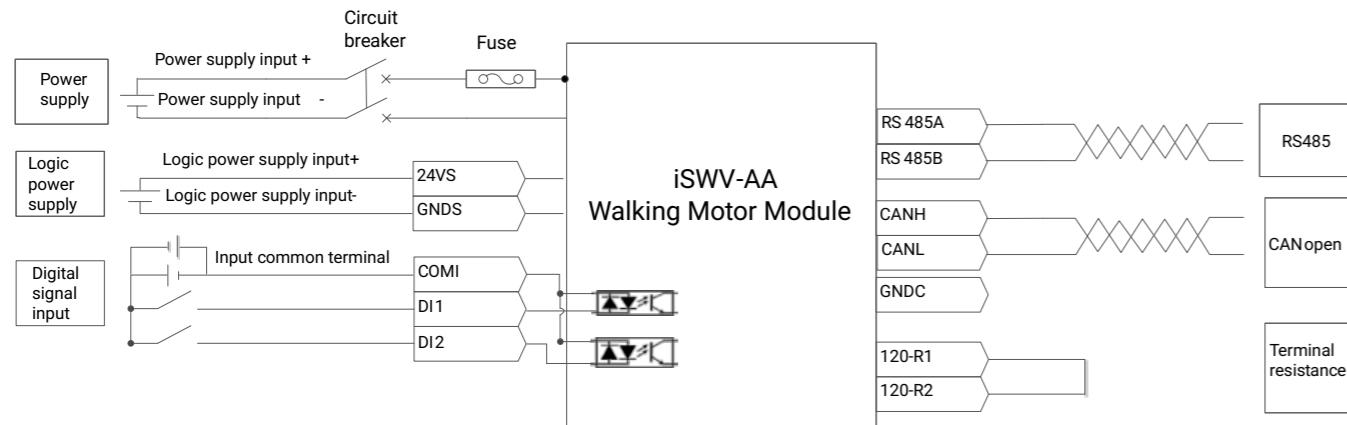

Note: When using the sensor(SEN),The logic power supply must be connected.
This is a customized function, standard iSWV product do not have this function

iSWV series electrical wiring

■ iSWV-EA electrical wiring

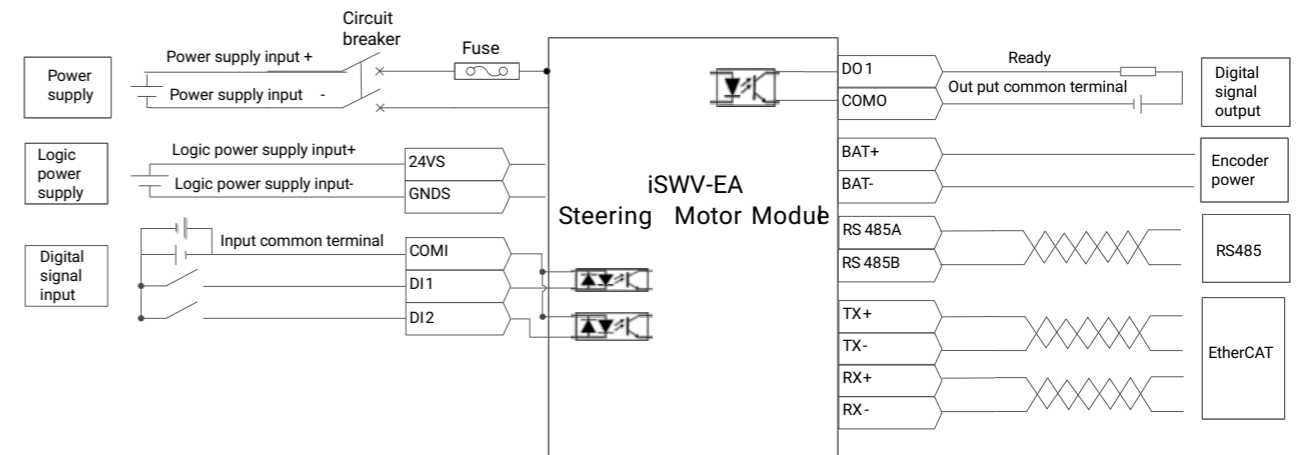
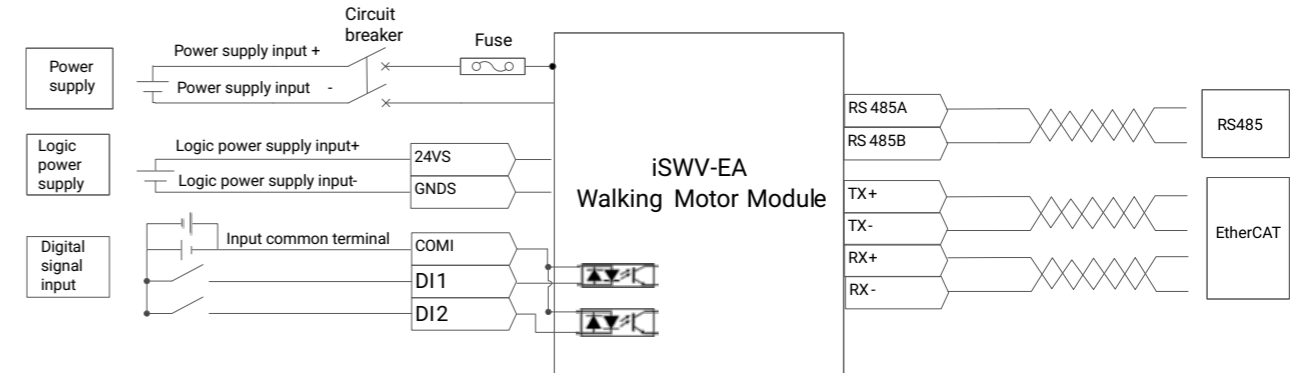

iSWV-AA Mechanical Dimensions

Integrated Module

iSWV00928-00627-A130-MADT-AA (Unit : mm)

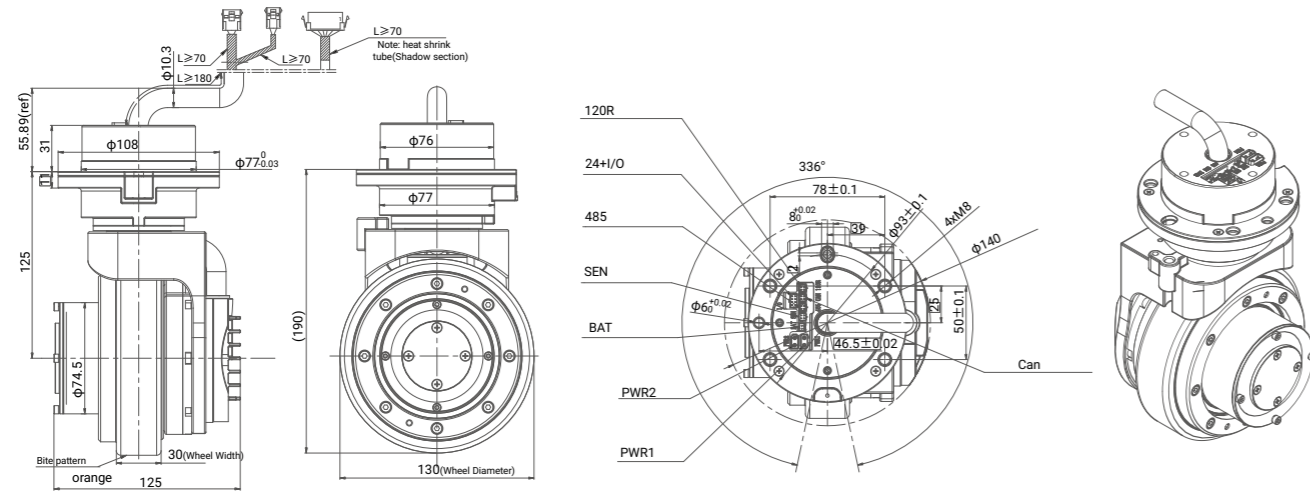

Walking Motor Module

iGML06010-00928-A130-MADT-AA (Unit : mm)

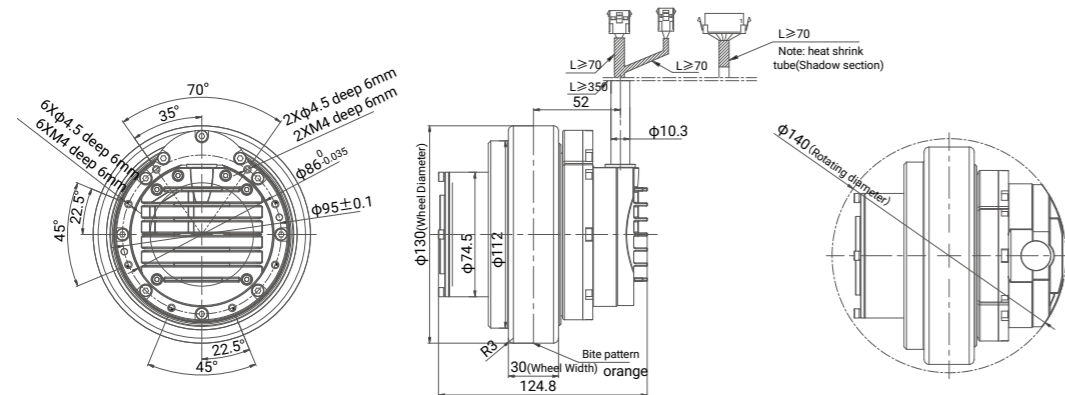

Steering Motor Module

iGMH06809-00627-LADR-AA (Unit : mm)

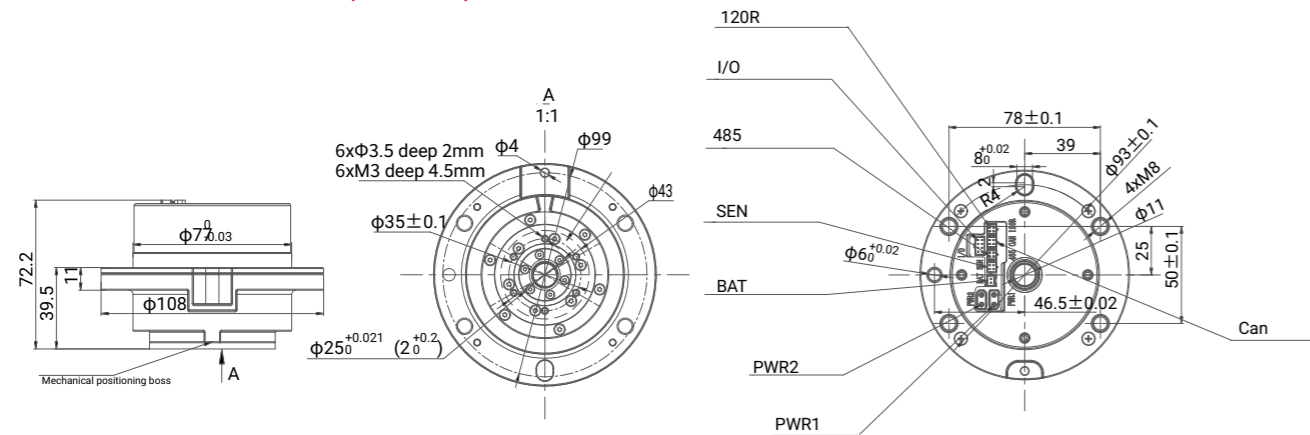

iSWV-EA Mechanical Dimensions

Integrated Module

iSWV00928-00627-A130-MADT-EA (Unit : mm)

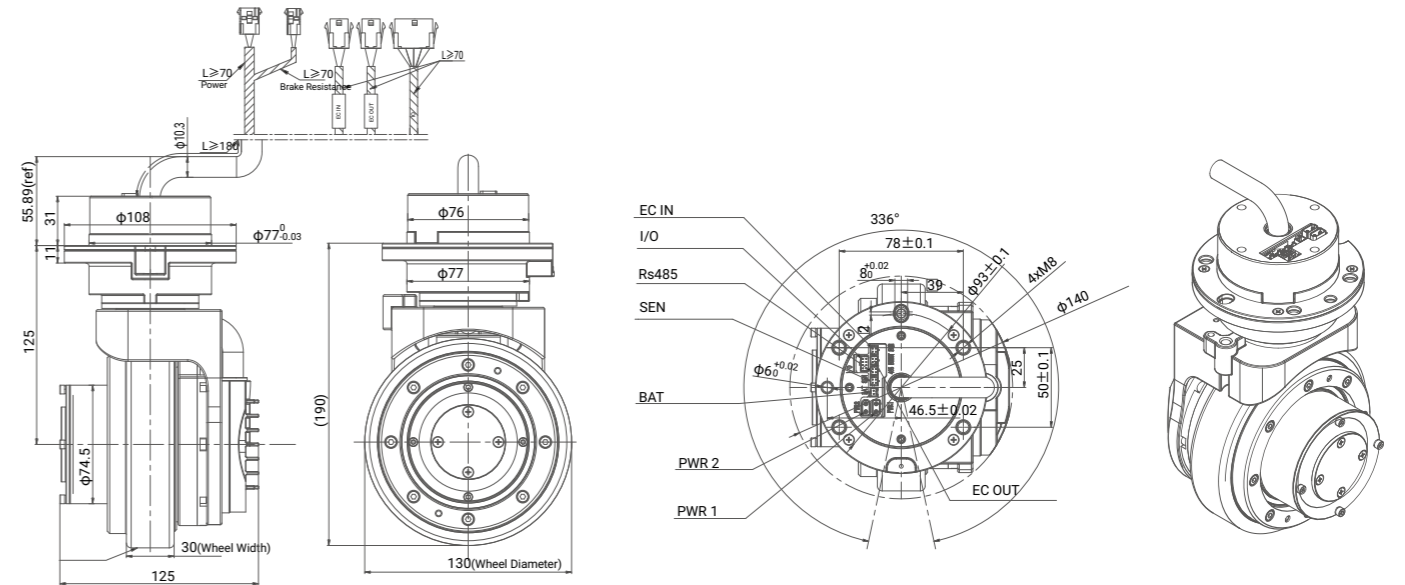

Walking Motor Module

iGML06010-00928-A130-MADT-EA (Unit : mm)

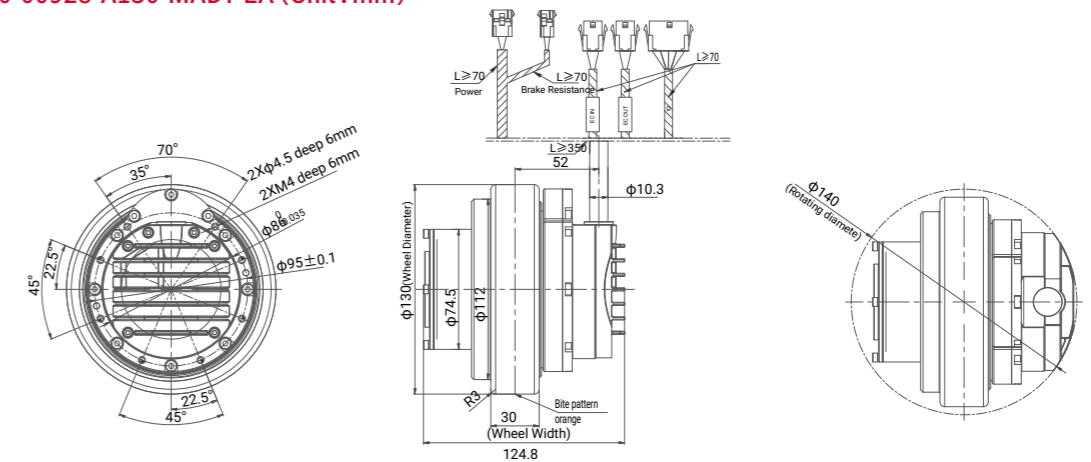

Steering Motor Module

iGMH06809-00627-LADR-EA (Unit : mm)

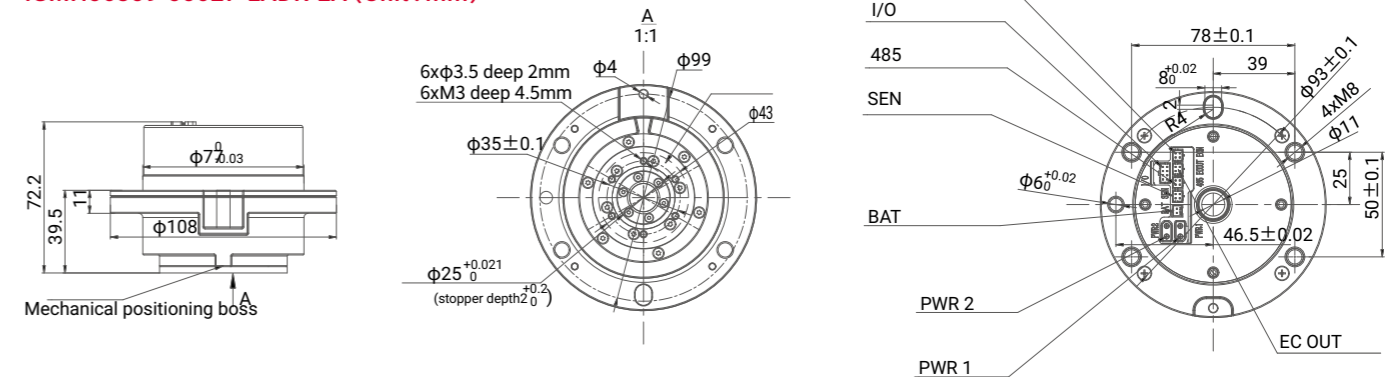

iSWV series T-N curve

Rotating T-N curve

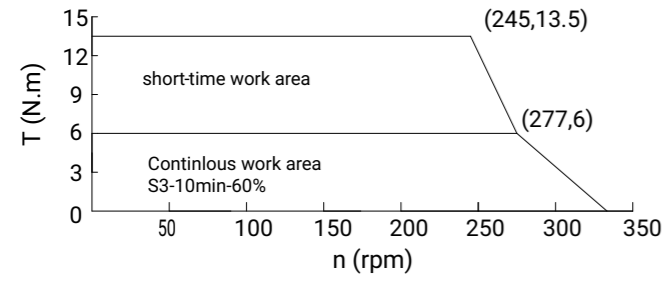

Walking T-N curve

